

electriciQ

USER MANUAL



DESICCANT DEHUMIDIFIER DESD8LW

Thank you for choosing electriciQ.
Please read this user manual before using this innovative dehumidifier and keep it safe
for future reference.

CONTENTS

SAFETY INSTRUCTIONS	3
FEATURES	6
PRODUCT OVERVIEW	7
POSITIONING THE DEHUMIDIFIER	8
CONTROL PANEL	9
WATER DRAINAGE	10
SETTING UP THE APP	12
CONNECTING TO THE APP	15
CONTROLLING YOUR DEVICE	17
SMART SCENES AND AUTOMATION	19
CONNECTION TROUBLESHOOTING	21
CARE AND MAINTENANCE	22
TROUBLESHOOTING	23
TECHNICAL SPECIFICATION	24
SUPPORT	25

SAFETY INSTRUCTIONS

IMPORTANT

- Carefully read the instructions before operating the unit.
- This appliance is only intended for use in an indoor domestic environment. Any other use is not recommended by the manufacturer and may cause fire, electrical shock or other injuries to person or damage to property.
- Rating: This unit must only be connected to a 220-240V earthed outlet. Installation must be in accordance with the regulations of the country where the unit is used.
- If you are in any doubt about the suitability of your electrical supply, have it checked and, if necessary, modified by a qualified electrician.
- This dehumidifier has been tested and is safe to use. However, as with any electrical appliance – care must be taken during use.
- Disconnect the power from the appliance before dismantling, assembling or cleaning.
- Avoid touching any moving parts of the appliance.
- Never insert fingers, pencils or any other objects through the guard.
- This appliance is not intended for use by persons (including children) with reduced physical, sensory or mental capabilities. It is also not intended for use by those with a lack of experience and knowledge unless they have been given supervision or instruction concerning the use of the appliance by a person responsible for their safety.
- Do not leave children unsupervised with this appliance.
- Do not clean the unit by spraying it or immersing it in water.
- Never connect the unit to an electrical outlet using an extension cord. If a power outlet is not available, one should be installed by a qualified electrician.
- Never operate this appliance if the cord, power adapter or plug is damaged. Ensure the power cord is not stretched or exposed to sharp object/edges.
- A damaged power supply cord should be replaced by the manufacturer or a qualified electrician in order to avoid a hazard.
- Any service other than regular cleaning or filter replacement should be performed by an authorized service representative. Failure to comply could result in a voided warranty.
- Do not use the appliance for any purpose other than its intended use.
- Do not tilt the unit while in use. The unit is designed to work only in a vertical position. This dehumidifier must always be stored upright, otherwise irreparable damage may be caused.
- This unit will still operate for approximately 3-4 minute after pressing the power button to turn off. This is normal and ensures the desiccant wheel is drained of water. Avoid restarting the dehumidifier until 5 minutes have passed after being turned off.
- Never use the mains plug as a switch to start or turn off the dehumidifier. Use the provided power button located on the control panel.

- Always place the unit on a dry and stable surface.
- The appliance should not be installed in a laundry or wet room where the humidity is higher than 85% RH. This unit should be operated at an ambient temperature between 1°C and 32°C.
- Do not dry laundry directly above the unit. To prevent water from entering the dehumidifier, laundry should be placed at least 40 cm away from your dehumidifier.
- Do not place the unit next to heat sources (e.g. electrical fires, fireplaces, etc.)
- Desiccant dehumidifiers tend to absorb odours from the surrounding environment like cigarettes, cooking, cosmetics, new furniture etc. This smell is described as a burning or sour smell. This is released during operation as the zeolite disc is heated. This is not a sign of a fault and the smell will fade after usage.
- Do not store or use gasoline, petrol, paint, solvents or other flammable vapours and liquids in the vicinity of this dehumidifier or any other appliance. Do not use dehumidifiers where flammable gases or VOC can be released or accumulate. Avoid mishandling the dehumidifier. Dropping, throwing the unit can cause damage to its internals and increases the risks of operating it.
- The handle on the appliance is designed to aid in its movement and should not be used to support the full weight of the dehumidifier. When carrying the unit, it should be kept upright and sufficiently supported from its base.

- Due to continuous product development the layout and availability of features within the app may vary.

ENERGY SAVING AND UNIT SAFETY PROTECTION TIPS

- Do not cover or restrict the airflow from the outlet or inlet grills.
- For maximum performance, the unit should be operated at least 20 cm away from walls and 50 cm from other objects within the room.
- Keep the filters and grills of the appliance clean. Under normal conditions, filters and grills should only need cleaning once every three weeks (approximately). Do not use the unit without the mesh air filter as this will allow dirt to gather inside the dehumidifier, which could invalidate the warranty.
- A dirty filter will restrict the airflow into the machine, which will increase the resistance on the fan and could result in damage and might invalidate the warranty.
- Since the filters remove airborne particles, more frequent cleaning may be necessary depending on the air quality. Vacuum and wash the mesh filters with hot soapy water and dry them before placing them back in the unit.

VISUAL SAFETY GUIDE

WHERE OR WHEN NOT TO USE YOUR DEHUMIDIFIER



Exposed to the weather outdoors



Near water



If the power cable wires are frayed or cut



Where small children may be left unattended



If an extension lead may become overloaded

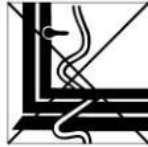

Where the power cable may be damaged



On a slope or uneven surface



Where there is risk of fire or close to a naked flame



Where it may be damaged by chemicals

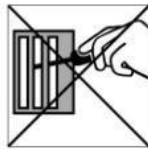

Where there is a risk or interference by foreign objects



This product is not made for DIY repair



If there is a risk of water falling on the unit

FEATURES

Your DESD8LW is a high quality desiccant dehumidifier with features not found in other units.

1. Efficient, easy to use and quiet.
2. Intelligent CPU controlled digital humidistat with 3 modes (Low, Mid and High),
3. Control and monitor the humidity or temperature remotely using your Android or Apple phone / tablet.
4. Alexa and Google home compatible: use voice commands to conveniently operate the smart dehumidifier.
5. Advanced scheduling abilities using the App.
6. Easy to use control panel with LED indicators.
7. Works very well at low temperatures compared with classic compressor dehumidifiers.
8. Heats the air passing through by between 5-10°C, making the air dry and warm reducing heating bills.
9. Ioniser creates negative ions which cause floating particulates such as dust, pet dander and allergens in the air, to cling together removing them from the air.
10. Swing feature allows direction of air flow to be adjusted.
11. Tank full alarm & auto-stop function.
12. Anti-tip switch to protect the machine should it be accidentally tipped over.
13. Recessed carry handle for portability.

The DESD8LW desiccant dehumidifiers uses compressor-free desiccant technology to extract water from the environment. Desiccant dehumidifiers are ideal both at standard and low temperatures working in an ambient temperature range of between 1-32°C. The DESD8LW is light and easy to move, as it does not contain a heavy compressor. It also works intelligently as it is designed to extract unwanted humidity while saving money due to its advanced power saving logic.

It features an intelligent digital humidistat with variable humidity selectable between 50% and 60% RH, ensuring your room is not over dried, and power is not wasted. Alternatively the Auto mode can be selected to run continuously.

PRODUCT OVERVIEW

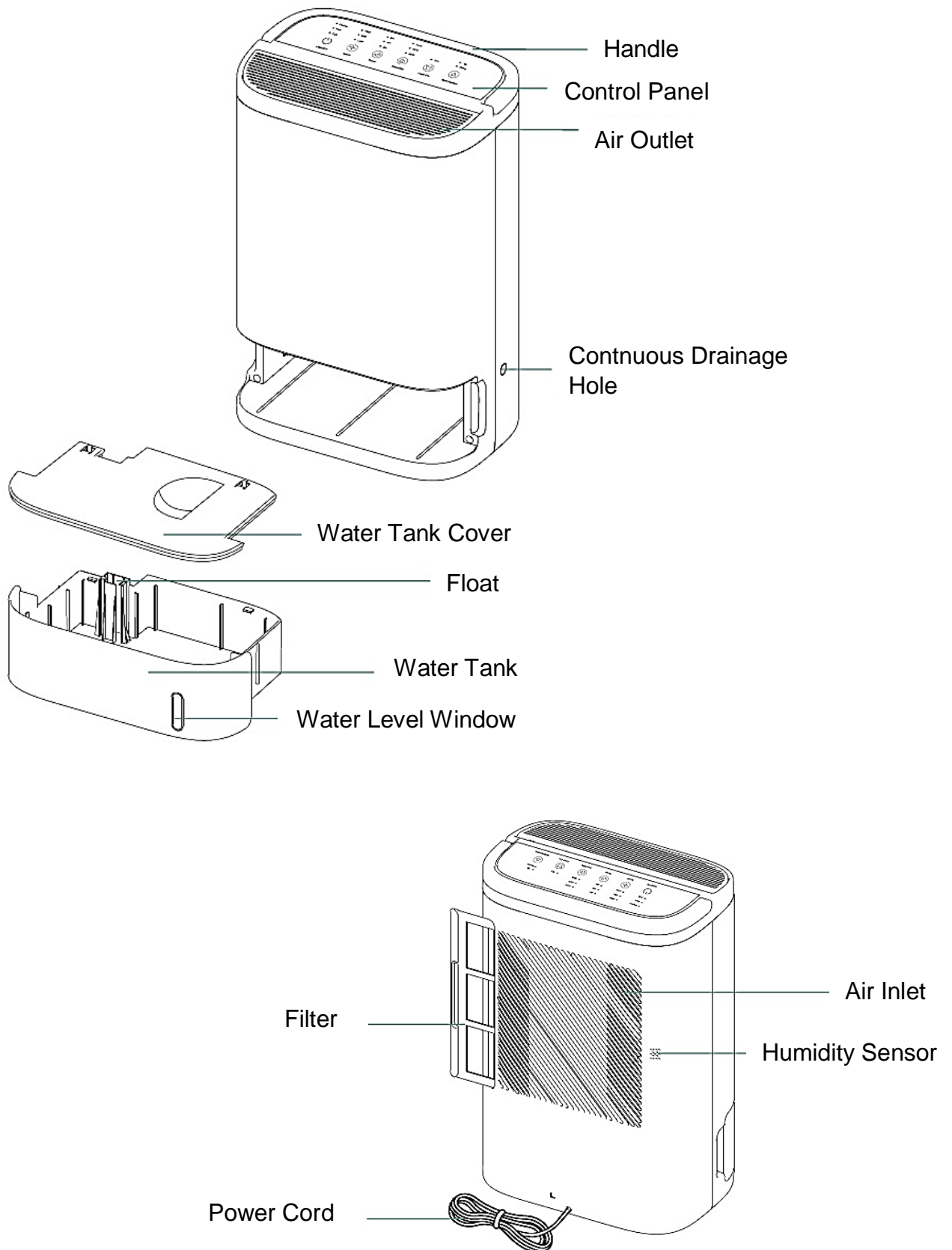

POSITIONING THE DEHUMIDIFIER

A badly positioned dehumidifier will have little effect. In positioning the dehumidifier please ensure circulation of the air is not restricted around the unit. At least 20 cm space should be allowed around the unit.



This dehumidifier is designed for indoor residential / small office applications only and any commercial or industrial use will invalidate the warranty.

Use the dehumidifier in an enclosed area for maximum efficiency. Close all external doors and windows to create an effective operating environment. Do not use outdoors.

Your electriQ dehumidifier will begin to protect your space from the harmful effects of excessive moisture as soon as it is turned on. Excess moisture is dispersed throughout your home. For this reason, the dehumidifier should be positioned in a central and clear location so that it can draw this moist air towards it. A warm hallway or landing is an ideal position for your dehumidifier. If possible, leave interior doors ajar to allow air circulation between rooms.





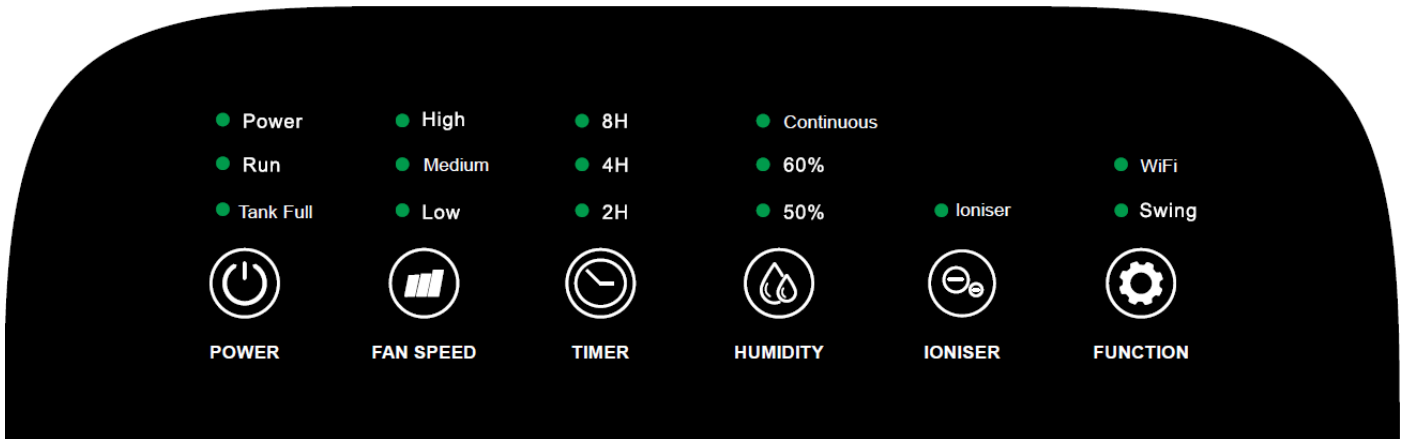

Alternatively, if you have a serious problem in one area you can begin by positioning the dehumidifier in that area and moving it to a more central location at a later date. Please note the unit should not be placed directly against a radiator or other heat source. When positioning your electriQ dehumidifier, ensure that it is placed clear of any obstacle that may limit the air movement, and ensure it is placed on a dry flat surface.

INSTALLATION

Remove any water from the water tank before starting the unit. In order to save energy, do not open windows or doors while the unit is running. Place the unit on a hard / flat surface. We would advise the unit be left to run continuously for 24 hours on its first use.

CONTROL PANEL



 POWER	<p>POWER BUTTON Press to turn the appliance ON and OFF. The POWER indicator illuminates when the unit is turned on, The RUN indicator will illuminate while the unit is dehumidifying and the TANK FULL indicator will illuminate when the unit has stopped due to a full water tank.</p>
 FAN SPEED	<p>FAN SPEED BUTTON Changes the fan speeds between High, Medium and Low. The corresponding indicator will illuminate above to show the currently selected fan speed.</p>
 TIMER	<p>TIMER BUTTON The timer can be set in 2 hour increments between 2 hours and 14 hours. The addition of the illuminated indicators shows the duration of the timer. i.e. if 2h and 4h are illuminated, the timer is set to 6 hours. WHILE RUNNING: Repeatedly press the TIMER button to set in how many hours the unit will turn off. Note: If the water tank fills during operation of the timer, the timer will stop until the water tank has been emptied, before resuming the countdown. WHILE IN STANDBY: Repeatedly press the TIMER button to set in how many hours the unit will start. Note the unit will start with the previously used settings.</p>
 HUMIDITY	<p>HUMIDITY BUTTON Alternate between RH50%, RH60% and Continuous. Once the humidity level falls below the target of 50% or 60%, the unit will stop dehumidifying until the humidity rises. The Continuous setting ensures the appliance will not stop dehumidifying and is ideal for laundry in conjunction with the high fan speed.</p>
 IONISER	<p>IONISER BUTTON The ioniser button creates negative ions which cause floating particulates such as dust, pet dander and allergens in the air to cling together removing them from the air.</p>
 FUNCTION	<p>FUNCTION BUTTON Here the swing function can be controlled, either swing or stop, stopping at any angle within 70 degrees. The FUNCTION button is also used for configuring the WiFi function.</p>

WATER DRAINAGE

The water tank has a maximum capacity of 2.5L with a 7L per day working capacity. When the water tank is full, the unit will stop operating. When this happens, the TANK FULL light will flash on the control panel, and the unit will beep.

Note: Only empty the water tank when it is full or before moving or storing the unit. There are two ways to dispense collected water.

USE THE INTERNAL WATER TANK

When the tank is full, the unit will stop running, and the TANK FULL indicator light will display. Grip the tank securely and carefully slide it out of the unit. Empty the water tank and reinsert it into the dehumidifier. The tank must be in place and securely seated for the dehumidifier to operate again. The dehumidifier will re-start when the tank is restored to its correct position.

EMPTYING THE WATER TANK:

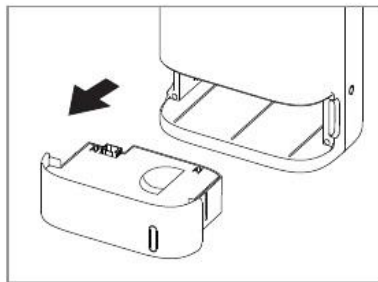

1. Take out the water tank

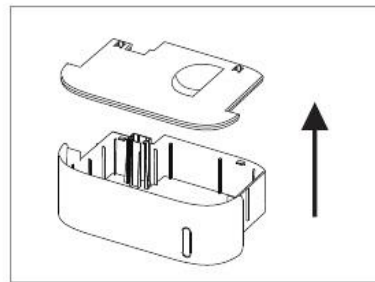

2. Remove the water tank cover

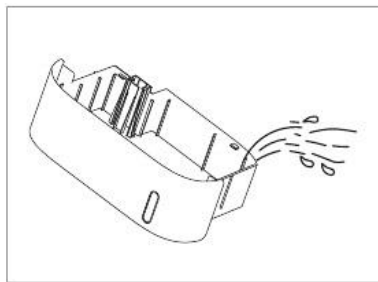

3. Empty the water

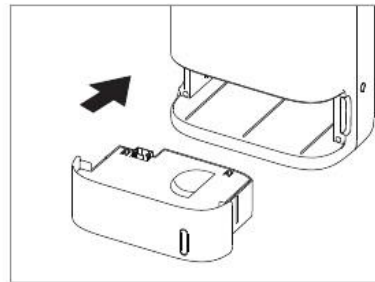

4. Reset the tank and it will restart

NOTES:

- Do not remove the water tank immediately after the unit stops. Please wait a while to avoid the water dripping into the unit and causing damage.
- Only empty the water tank when it is full or before moving or storing the unit.
- Do not rest the tank on the floor because the bottom of the tank could be uneven and the tank may fall, causing water to spill.
- When you remove the tank, do not touch sensors or any parts which are situated behind the tank. Doing so may damage the product. Be sure to push the tank gently all the way into the unit. Banging the tank against anything or failing to push it securely into place may prevent the unit from operating.
- Do not remove or damage the float switch in the water tank, otherwise the machine will stop working.
- Please make sure the water tank cover is put back into place correctly before the water tank is reinserted.
- If the water tank is inserted incorrectly, the full tank indicator will illuminate. Remove the water tank and reinsert to turn the indicator off and resume normal use.
- At all times, avoid water entering the unit. It may cause an electrical hazard and damage the unit.

SET UP CONTINUOUS DRAINAGE

The dehumidifier has a continuous drain hole that can be connected to a plastic pipe with a 14 mm inner diameter (not supplied). Water can be drained into a large receptacle or sink, for example, or through the wall into an outside drain. Please follow the steps below to set your unit up for continuous drainage.

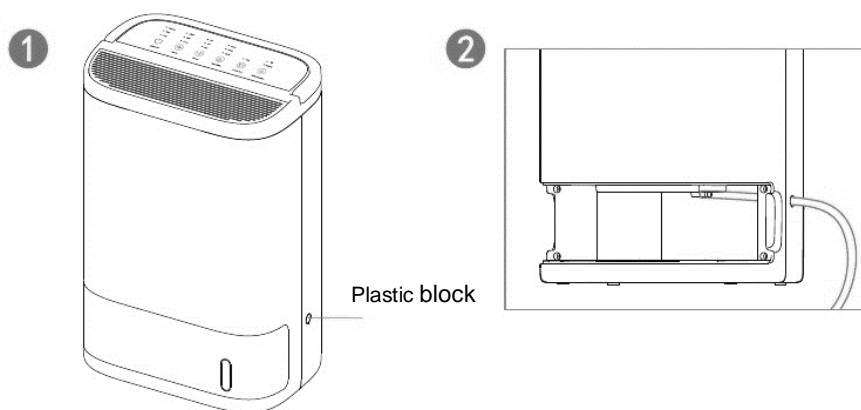

1. Cut off the cover for the continuous drain on the back of the unit.
2. Remove the water tank and connect a water tube with an inner diameter of 14mm to the drain connector, and ensure the connection is tight
3. Replace the water tank into position within the unit.

This unit uses gravity to dispose of the water collected and as such the drain should be lower than the dehumidifier water outlet. Be sure to run the water pipe downwards and let the water flow out smoothly. Do not kink or bend the pipe.

NOTES:

- When the continuous drain feature is not being used, remove the pipe installation, to start the water collecting in the water tank.
- The permanent drain can be used in conjunction with a water pump (e.g. when draining from a cellar) to lift the water upwards.

SETTING UP THE WIFI APP

BEFORE YOU START

- Ensure your router provides a standard 2.4GHz connection.
- If your router is dual-band ensure that both networks have different network names (SSID). The provider of your router / Internet service provider will be able to provide advice specific to your router.
- Place the dehumidifier as close as possible to the router during setup.
- Once the app has been installed on your phone, turn off the data connection, and ensure your phone is connected to your router via WiFi.

DOWNLOAD THE APP TO YOUR PHONE

Download the "TUYA SMART" app, from your chosen app store, using the QR codes below, or by searching for the app in your chosen store.



Android



IOS

CONNECTION METHODS AVAILABLE FOR SETUP

The smart device has two different setup modes, CF (Quick Connection) and AP (Access Point). The quick connection is a quick and simple way to set the unit up. AP connection uses a direct local wifi connection between your phone and the dehumidifier to upload the network details.

Before starting the setup, please ensure that your dehumidifier is in the correct standby mode for the connection type you are attempting, the display your dehumidifier will indicate this.

To connect to the WIFI, press and hold the FUNCTION button when the unit is in standby mode for approximately 7 seconds

CHANGING BETWEEN CONNECTION MODES / WIFI RESET

To change the unit between the two connection types, hold the FUNCTION button for 7 seconds. The connection mode is signified by the frequency of the flashing Smart light. This will also remove any previous WIFI configuration.

Connection Type	Frequency of Flashes
CF (Quick Connection)	Flashes twice per second
AP (Access Point)	Flashes once per second

REGISTER THE APP

1. Press on the register button at the bottom of the screen.

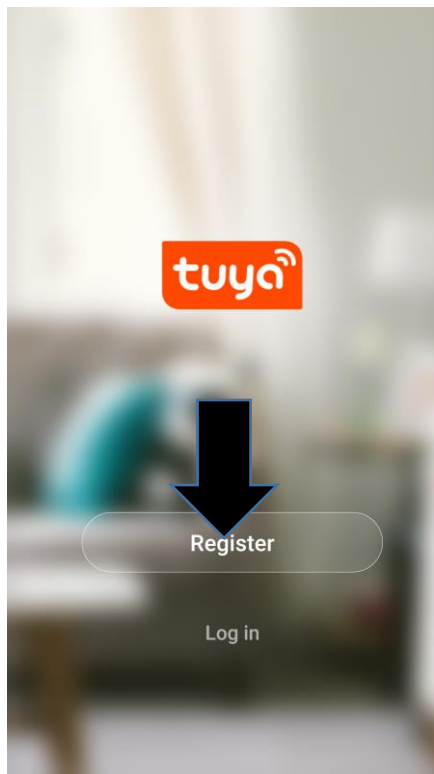

2. Read the Privacy policy and press the Agree Button.

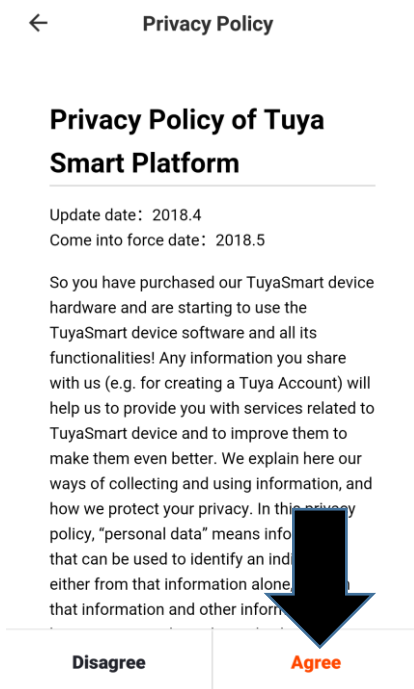

3. Enter your email address or phone number and press continue to register.

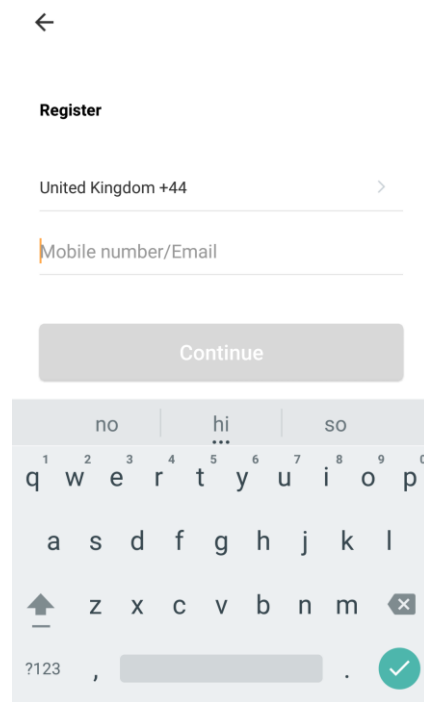

4. A verification code will be sent by the method selected in step 3. Enter the code into the app.

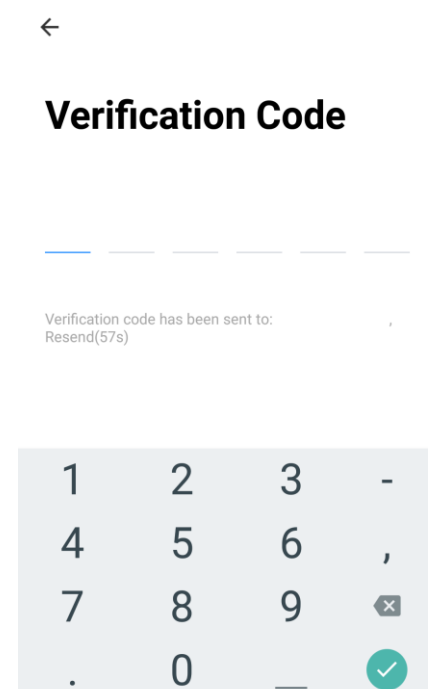

5. Type in the password you would like to create. This needs to be 6-20 characters, with letters and numbers.

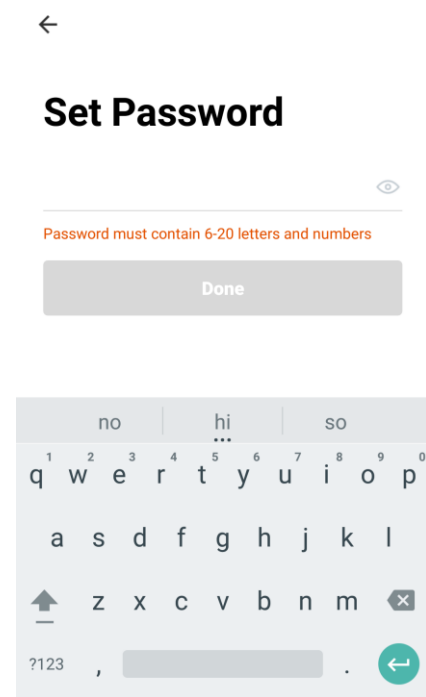

6. The app is now registered. It will automatically log you in following registration.

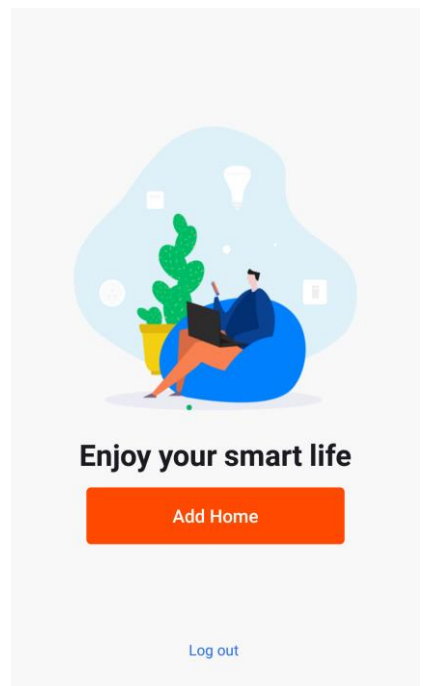

SETTING UP YOUR HOME WITHIN THE APP

TUYA is designed so it can work with a large number of compatible smart devices within your home. It can also be set up to work with multiple devices within different houses. As such, during the setup process the app requires that different areas are created and named to allow easy management of all your devices. When devices are then added, they are assigned to one of the rooms you have created.

CREATING ROOMS

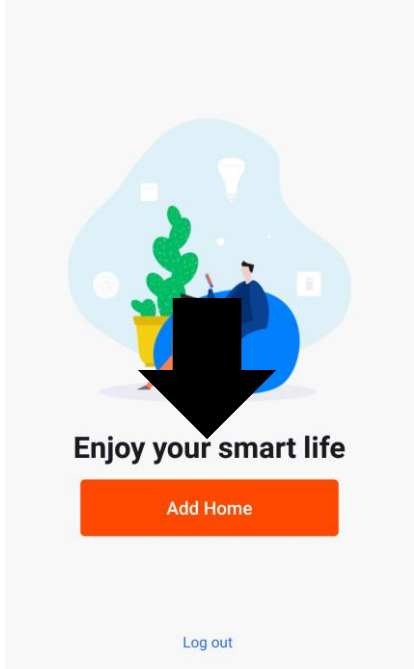
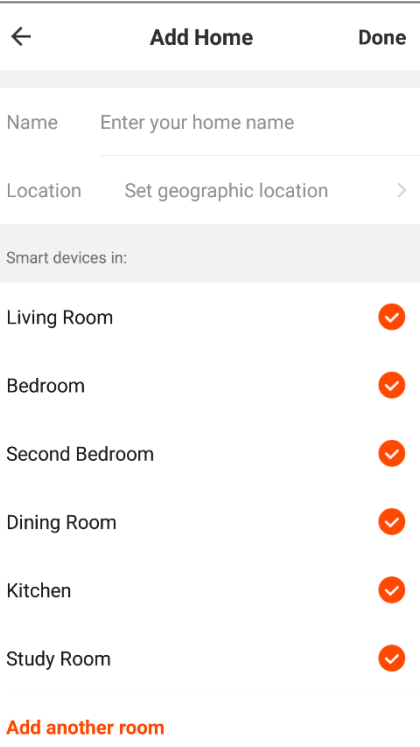
<p>1. Press on the ADD HOME button.</p> 	<p>2. Type in a name for your home, 3. Press on the location button to select the location of your home. (See SETTING YOUR LOCATION below) 4. New rooms can be added by pressing the ADD ANOTHER ROOM option at the bottom. (See ADD ANOTHER ROOM below) 5. Untick any rooms that are not required on the app. 6. Press DONE in the top right corner.</p>	
--	---	--

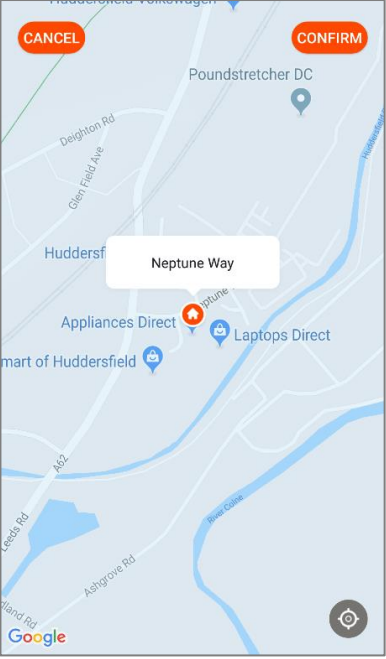
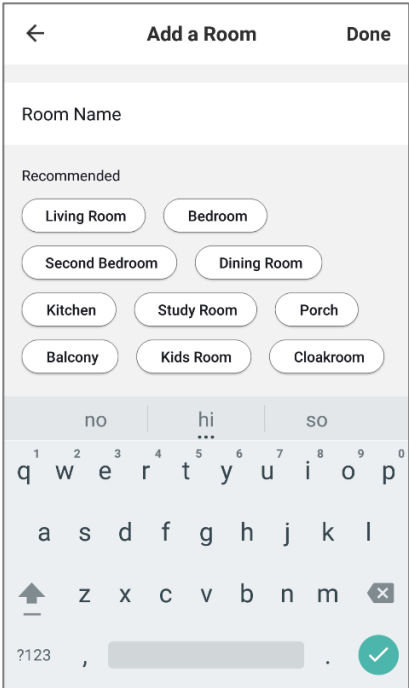
<h3>SETTING YOUR LOCATION</h3> <p>Use your finger to move the orange HOME symbol.</p> <p>When the symbol is in the approximate location of your home, press the confirm button in the top right corner.</p> 	<h3>ADD ANOTHER ROOM</h3> <p>Type in the name of the room, and press Done in the top right corner</p> 
---	---

CONNECTING USING QUICK CONNECTION

Before initiating the connection, make sure the unit is in standby mode, with the WiFi light flashing twice per second. If not, follow the instructions for changing the connection mode. Ensure your phone is connected to the WiFi network. (We advise turning mobile data off during setup)

1. Open app and press “+” to add device, or use the add device button

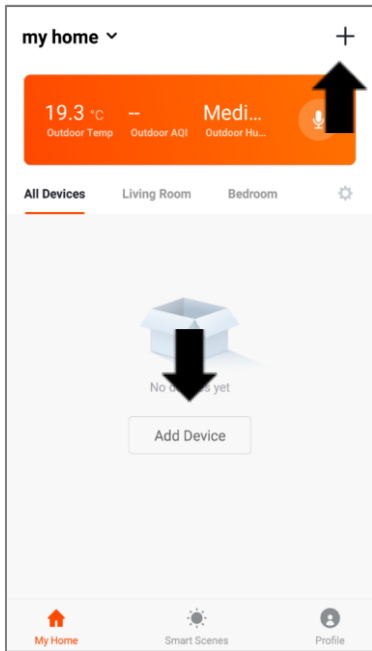

2. Select the type of device as “Dehumidifier” in the Small Home Appliance tab.

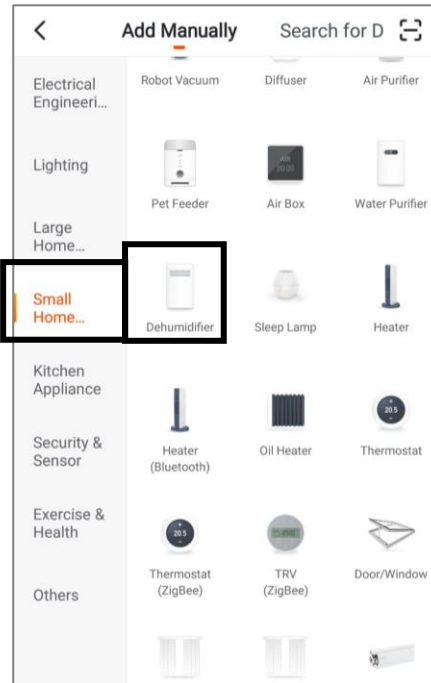

3. Ensure the WiFi light on the dehumidifier is flashing twice per second, then press on the orange button at the bottom of the screen to confirm.

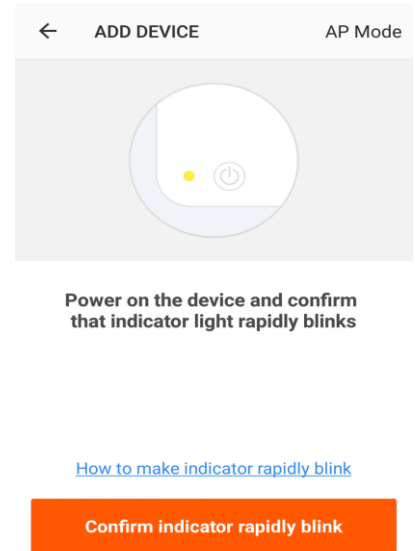

4. Enter your WiFi password and press confirm.

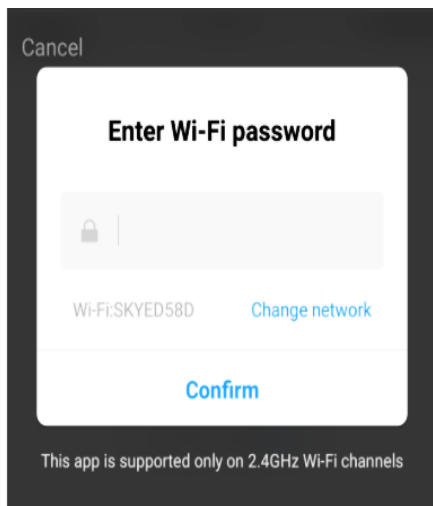

5. This will then transfer the settings to the dehumidifier. Wait for this to complete. If this fails, retry. If still unsuccessful please review the troubleshooting section for further help.

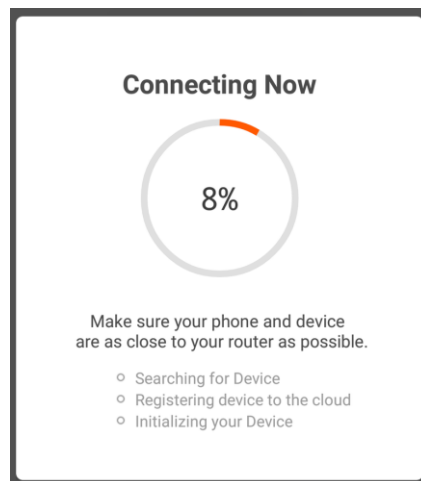

CONNECTING USING AP MODE (ALTERNATIVE METHOD)

Before initiating the connection, make sure the unit is in standby mode, with the WiFi light flashing once per second. If not, follow the instructions for changing the connection type. Ensure your phone is connected to the WiFi network. (We advise turning mobile data off during setup)

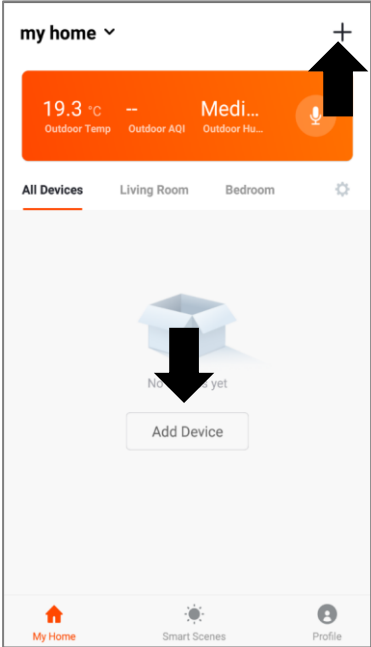
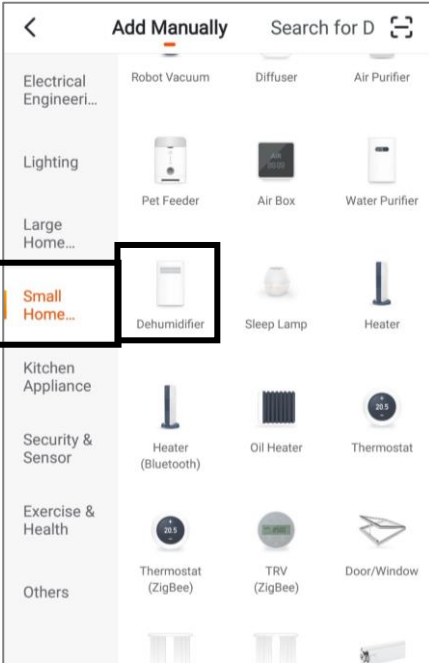
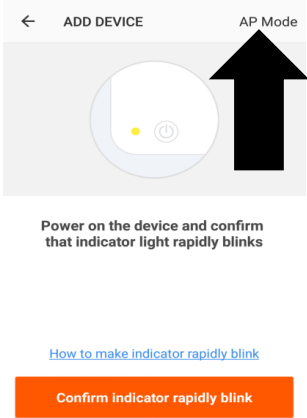
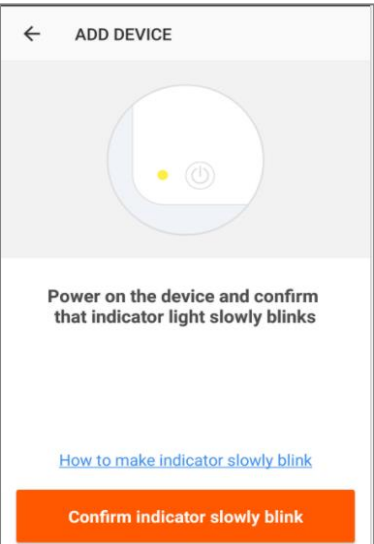
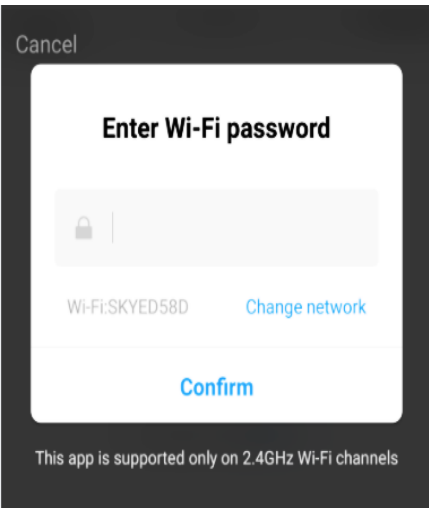
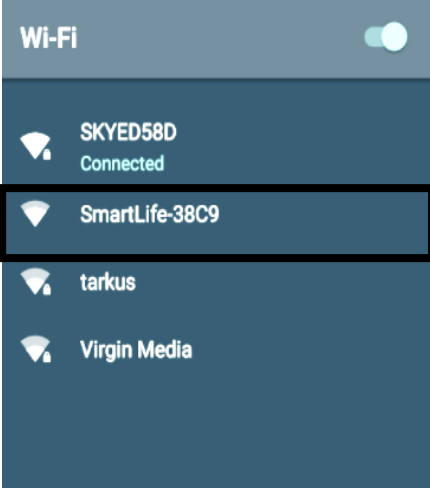
<p>1. Open app and press “+” to add device, or use the add device button</p> 	<p>2. Select the type of device as “Dehumidifier”</p> 	<p>3. Press on the AP mode button in the top right of the screen.</p> 
<p>4. Ensure the WiFi light on the dehumidifier is slowly flashing (once per second), then press on the orange button at the bottom of the screen to confirm</p> 	<p>5. Enter your WiFi password and press confirm.</p> 	<p>6. Go to network settings in your phone and connect to the “SmartLife xxx” connection. There is no password to enter. Then return back to the app to complete setup.</p> 
<p>This will then transfer the settings to the dehumidifier. Once the connection process has completed, go back to the network settings on your phone to ensure your phone has reconnected to your WiFi router.</p>		

CONTROLLING YOUR DEVICE THROUGH THE APP

THE HOME SCREEN

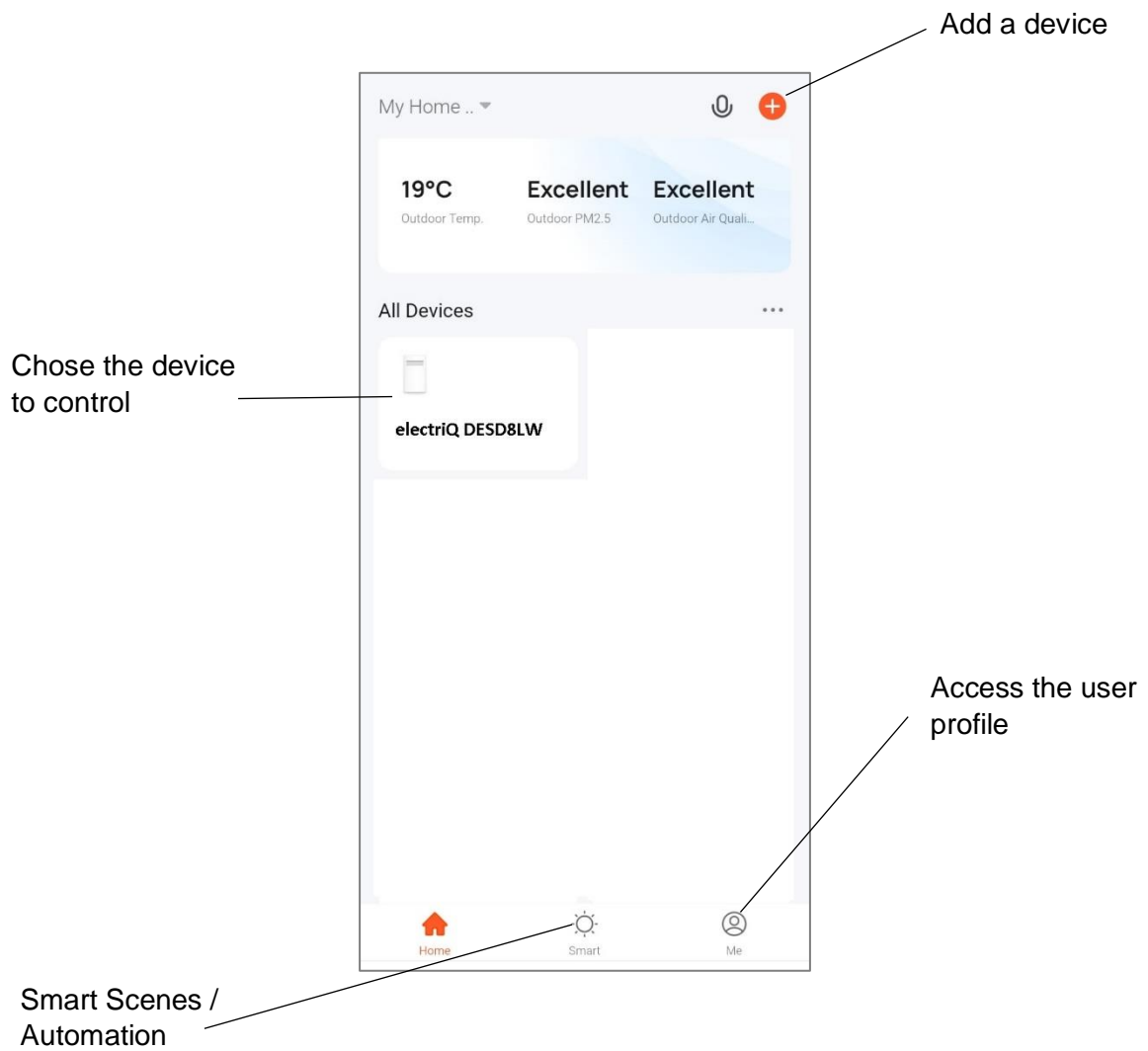

DEVICE SCREEN

The device screen is the main control screen for the dehumidifier, providing access to the controls to amend the functions of the dehumidifier

Back: Returns to the Home Screen

Set Humidity Level: Set the level from 30% to 80% using the + and – buttons.

Speed: shows currently selected fan speed

Power: Turn the unit on and off.

Speed Menu: Select the required fan speed (opens drop down menu)

Profile: Use to change the name of the dehumidifier and amend user settings.

Target Humidity: the humidity level you are aiming for

Indoor Humidity: Displays current humidity of the room

Settings: see below

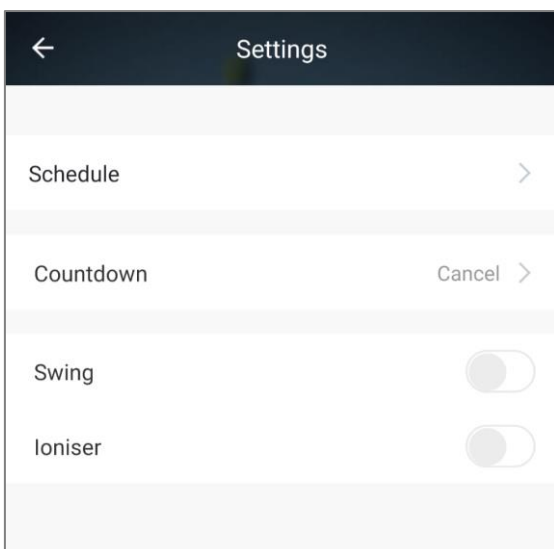
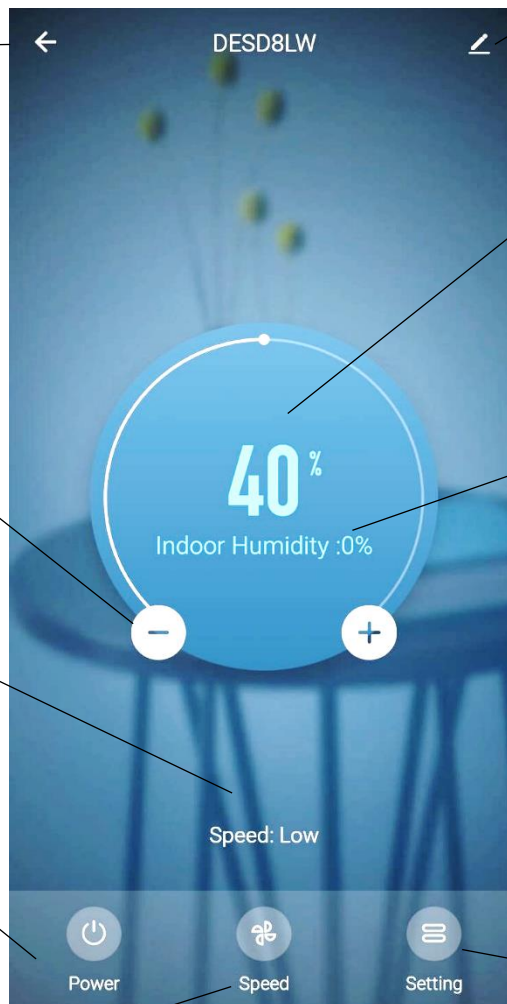

Schedule: Use the schedule to set up times when the device will turn on or off.

Countdown: set a time period for the to shutdown.

Swing: Activate and de-activate the movement of the louvres.

Ioniser: Turn on and off the Ioniser feature.

SMART SCENES

Smart Scenes is a powerful tool providing the option to customise the operation of the dehumidifier based both on conditions within the room and outside influences. This gives the user the option of specifying much more intelligent actions. These are split into two categories Scene and Automation.

SCENE

Scene allows for a one-touch button to be added to the Home screen. The button can be used to change a number of settings in one go and can change all the settings within the unit. A number of scenes can easily be set up, allowing the user to easily change between a number of preset configurations.

Below is an example of how to set up a scene:

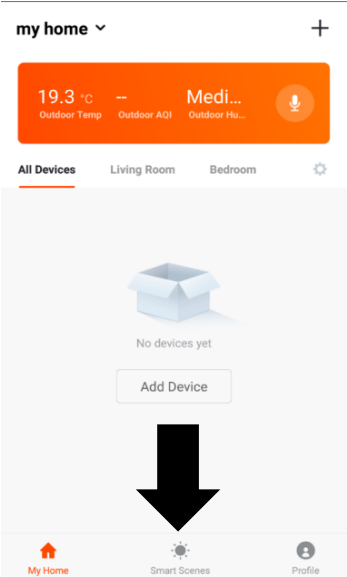
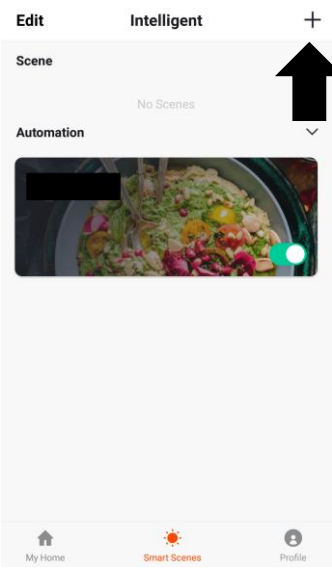
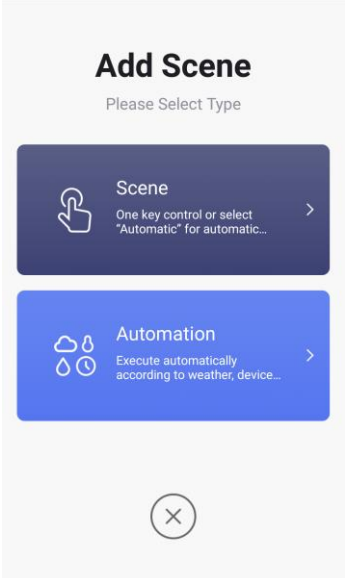
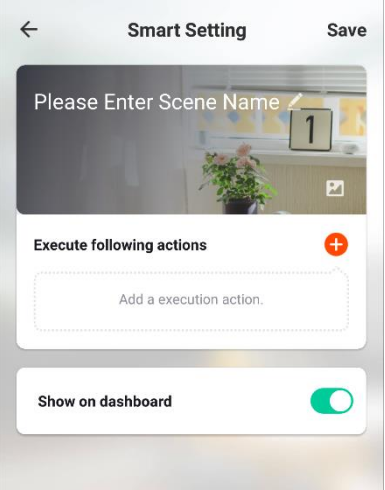
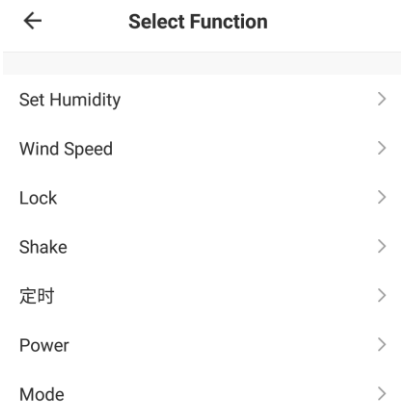
<p>1. Press on the Smart Scene tab at the bottom of the Home screen</p> 	<p>2. Press on the Plus in the top right corner to add a smart scene.</p> 	<p>3. Select Scene to create a new Scene</p> 
	<p>4. Press the Pen next to "Please Enter Scene Name" to input the name for your Scene</p> <p>Show on Dashboard: Leave this on if you require the scene to be displayed as a button on the Home Screen</p> <p>Press the Red Plus to add the action required. Then select the dehumidifier from the list of devices.</p>	<p>5. Chose the function, set the value for the function, and then press the back button in the top right corner, to return to the previous screen.</p> 
<p>6. Once all the functions required have been added, press the Save button in the top right corner to finalise and save your new Scene</p>		

AUTOMATION

Automation allows an automatic action to be set up for the device. This can be triggered by the Time, indoor temperature, humidity of the room, weather conditions, and a range of other influences.

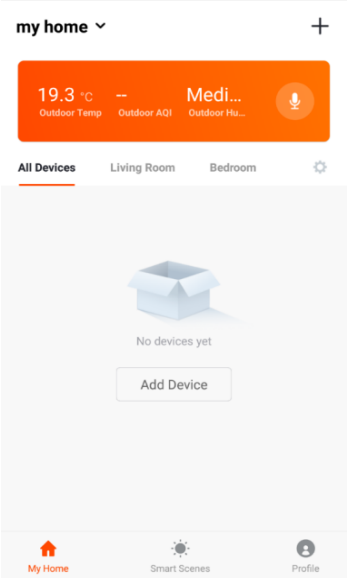
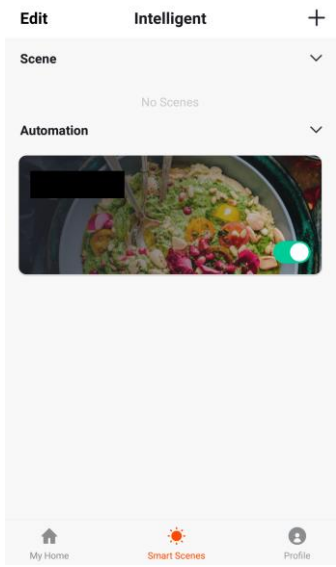
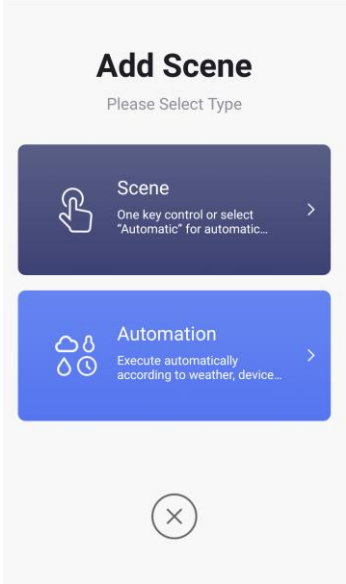
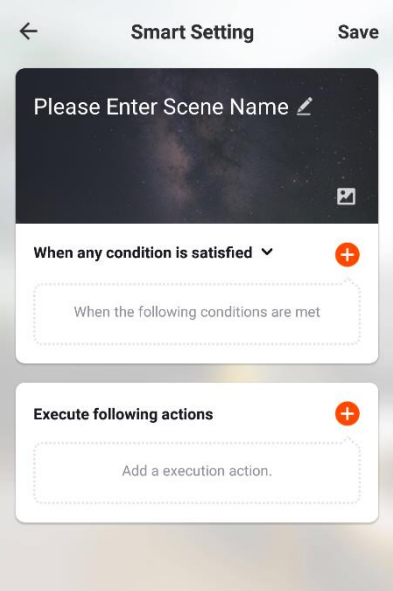
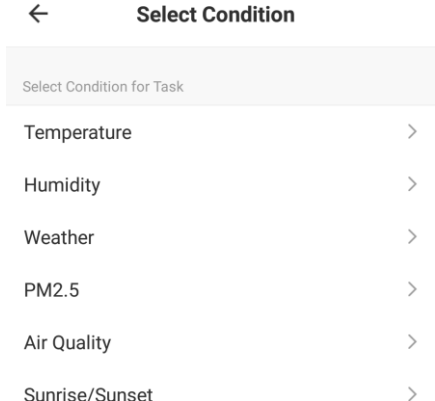
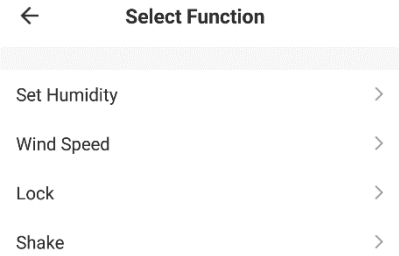
<p>1. Press on the Smart Scene tab at the bottom of the Home screen</p> 	<p>2. Press on the Plus in the top right corner to add a smart scene.</p> 	<p>3. Select Automation to create a new Automation Scene</p> 
<p>4. Setup is very similar to the scene setup on the previous page, and includes an extra section for specifying a trigger for the scene to start.</p>  <p>Press the Pen next to "Please Enter Scene Name" to input the name for your Scene</p> <p>Press the Red Plus next to "When any condition is satisfied" to add the trigger</p> <p>Press the Red Plus next to "Execute following actions" to add the action required. Then select the dehumidifier from the list of devices.</p>	<p>5. Select the condition when the automation should start. A number of triggers can be combined.</p> 	
<p>6. Chose the function, set the value for the function, and then press the back button in the top right corner, to return to the previous screen.</p>		<p>7. Once all the functions required have been added, press the Save button in the top right corner to finalise and save your new scene.</p> <p>The automation is now set up, it can be turned on and off using the toggle on the image shown on step 2.</p>

DEVICE DETAILS SCREEN

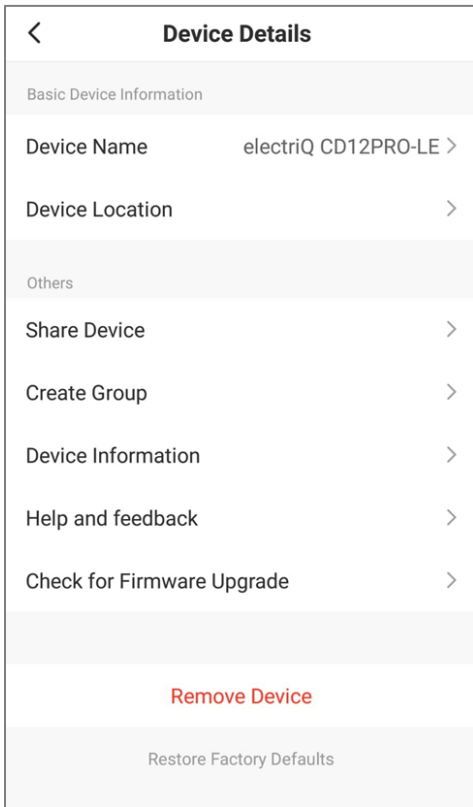

The device details screen gives you the option to edit the details for the device, and use some of its additional features. The device details screen can be accessed from the device screen by pressing on the symbol in the top right hand corner.

CHANGING THE NAME OF YOUR DEVICE

The top option within this allows you to change the name of the device to something relevant to the use of the product, such as “Living Room Dehumidifier”. Within the menu, you also have the option of setting up a pattern lock or change your password.

DEVICE SHARING

This allows you to share access to the controls of your dehumidifier with friends and family.

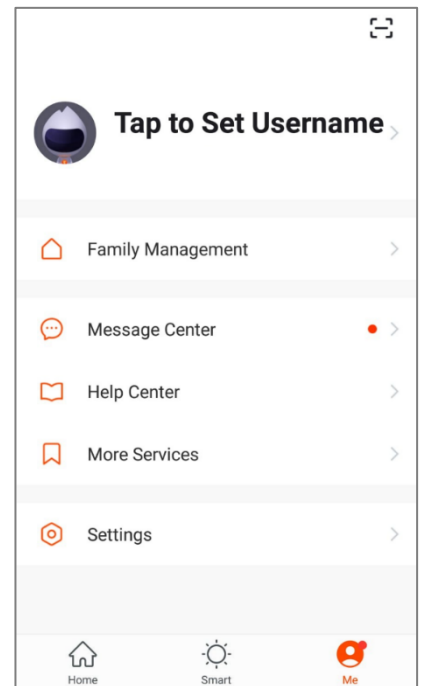

PROFILE TAB

The Profile tab allows you to make changes to the app, such as setting up a username and editing or adding rooms.

Within the Profile tab, you are also able to change settings related to the app itself.

CONNECTION TROUBLESHOOTING

1. Check whether the device is powered on and is in the correct standby mode, if not please refer to the CHANGING BETWEEN CONNECTION MODES section on page 12.
2. Ensure the wifi password has been entered into the app correctly (Case sensitive)
3. Check that the phone is connected to the wifi you are connecting the device to.
4. Ensure the network you are connecting it to is 2.4Ghz (5Ghz wifi networks are not supported), and that there is a strong wifi signal to the item.
5. If your router is dual band, ensure that the 2.4ghz network has a different network name (SSID). Further advice on changing router settings will be available from your Internet service provider / Router manufacturer.
6. Check the settings on the router. Encryption should be WPA2-PSK and authorisation type should be set to AES
7. Try using the alternative connection method. i.e. If connection is failing when attempting to connect through CF mode, try AP mode.

CARE AND MAINTENANCE

Always shut off the unit and unplug it from the mains before cleaning or performing any maintenance. When it is not in use for long periods, it is advisable to remove the plug from the power socket. Do not use chemical solvents (such as benzene, alcohol or gasoline) as they may cause irreversible damage to the unit.

FILTER CLEANING

The Air-inlet may gather dust easily, clean it often with a soft, damp cloth. If the filter is covered by dust, the airflow and the performance of the unit will be affected. It may even cause damage to the unit. We recommend that you regularly clean the filters. The dehumidifier must be disconnected from the socket before maintenance, and the filters must be allowed to fully dry before use.

1. Remove the filters from the unit, and tap the dust away.
2. Clean the mesh filter with a vacuum cleaner or a soft brush.
3. If dirt and grease have accumulated , wash the mesh filter in hot soapy water.
4. Replace the filters in position.

NOTE: Never use the unit without the mesh filter.

CLEAN THE WATER TANK

Every few weeks, clean the tank to prevent the growth of mould, mildew and bacteria. Partially fill the tank with clean water and add a little mild detergent. Swish it around before emptying the tank and rinsing.

NOTE: Do not use a dishwasher to clean the tank. After cleaning and drying the tank must be reinserted securely into the dehumidifier in order to restart operation.

END OF SEASON MAINTENANCE

1. Empty and clean the water tank.
2. Clean the unit and the filters as per the cleaning procedure above.
3. Cover the unit and keep it in a dry place.

POWER CORD MAINTENANCE AND REPLACEMENT

If the power cord is damaged, it could cause a short circuit or become a fire risk. Please avoid pulling the cord, twisting or pressing it and keep it away from pets. If the power cord is damaged, power the unit off and unplug it immediately. Contact an electrician or service centre for repair; do not attempt to repair the unit yourself.

TROUBLESHOOTING

Problem	Possible Cause	Solution
Unit does not work	Water tank displaced or full	Check water tank placement or empty water tank
	Room temperature is too high, or air-outlet is covered	Reduce room temperature, clear air outlet
Poor performance	Filter is dirty	Clean the filter
	Door & windows are open	Close door & windows
	Air-inlet or out-let is blocked.	Clean air-inlet & air-outlet
Too Noisy	Unit is on an uneven surface.	Place the machine on a flat surface. Add carpet or rubber mat underneath
	Filter is blocked	Clean the filter
The device does not dehumidify	The relative humidity in the room where the dehumidifier is operating is too low.	The dehumidifier dries down to the target relative humidity set and will then go into standby if the desired humidity has been reached.
The dehumidifier works, but relative humidity is still high	The place is too large. This dehumidifier can dry up to 40m ² .	We recommend using a dehumidifier with a greater capacity. Call customer service line for advice.
	There are too many sources of moisture. Bathing, washing, drying clothes and cooking all put moisture into the air.	We recommend using a dehumidifier with a greater capacity.
	Paraffin or Calor gas heating can add too much moisture into the air	Consider using alternative heat sources
The windows were clear, and now condensation has returned.	The outside air temperature has dropped significantly, and the windows are colder.	Set the dehumidifier to 50%RH and run for longer
I cannot remove the condensation from my windows, even in "Auto" mode	The surface temperature of the windows is too low for a dehumidifier to prevent condensation. Common with single glazed windows or poorly insulated houses when the outside air temperature drops below 0°C	Keep running the dehumidifier on "Auto" 24 hours a day and if the air temperature outside increases the condensation on windows may clear
The dehumidifier is blowing out warm air	The dried air is passed over a heating element before it is blown into the room as part of the dehumidification process	This is normal and helpful, especially in the cold weather; a dehumidifier is not an air cooler.
Knocking noise coming from the dehumidifier	The motor wheel is low on lubrication or dirt may have entered the motor ball bearings	Run the dehumidifier in Auto mode for two days to increase the lubrication, if the fault persists then call the service centre
Water not draining down the hose	The hose is fitted for continuous drainage, but the water still goes into the tank	Negative air pressure in the room is pulling the water back into the dehumidifier overflow.
		Insert a 3 mm hole into the top of the tube 25 mm down from the spout. This will introduce air into the tube and balance out the air pressure.
		Dirt is gathered in the internal tray. May need servicing. If the fault persists then call the service centre
Dehumidifier leaks water onto the floor	Usually means that the dehumidifier is not on a level surface or that the filter has not been cleaned often enough and dirt has fallen into the internal tray dehumidifier.	Check that the water bucket is not cracked by filling it with water and placing it on kitchen paper on the kitchen side.
		Check if filters are clean
		If the fault persists then call the service centre
Machine not switching off the heater when desired humidity is reached	Temperature and relative humidity sensor that reads the room reading is unable to read the correct readings	Clean the filter and blow the air sensor with a vacuum cleaner or hairdryer on the COLD setting to clear the sensor of dirt
		Unplug the dehumidifier for 10 minutes to reset PCB and then turn back on.
		If the fault persists then call the service centre
On pressing power off fan still works for several minutes and switches off	Unit is drying/cooling internally before going in off mode	Normal operation. DO NOT remove power until this has finished.

Note: when the fault cannot be solved by the solutions above, please contact the service centre for help, do not attempt repairs.

FREQUENTLY ASKED QUESTIONS

WHY DOESN'T THE UNIT WORK /OR STOPS SUDDENLY?

The water tank may be full or displaced. Empty the tank and carefully replace in the unit to rectify.

WHY DOES IT REQUIRE EMPTYING VERY REGULARLY?

When you first use your dehumidifier, it will work harder to reduce the room humidity down to 50%. This is the time when it will produce the most water and as such will require emptying most frequently (even 2-3 times /day). As the room becomes dryer, the dehumidifier will collect less water and it will take longer to fill the tank, this is perfectly normal. When the target relative humidity has been reached the dehumidifier will stop collecting water and will operate for longer periods in fan-only mode, this is normal operation. The intelligent logic of your machine will save you money.

WHAT DESIRED HUMIDITY SHOULD I SET THE DEHUMIDIFIER TO?

Unless you are using the unit to dry clothes, we recommend setting the desired humidity to between 50% and 60%.

For unoccupied properties, garages and etc, set the unit 60%RH with the fan in mid or low mode according to your needs. That will ensure minimum power consumption while preventing moisture-related issues.

THE ROOM HAS REACHED THE DESIRED HUMIDITY, BUT STILL HAVING PROBLEMS WITH CONDENSATION

If you find that you still have condensation on your windows or you need to dry the air further, set the unit to Auto (continuous) mode with the fan set to High mode. This may be necessary if you have single glazed windows, the house is poorly insulated or if the outside air temperature drops towards freezing. Using the unit in High mode will add more heat to your room and reduce your heating bill as dry air will heat quicker

TECHNICAL SPECIFICATIONS

Model No.	DESD8LW
Rated Voltage	220-240V ~ 50/60Hz
Dehumidify Capacity	20°C and 60%RH low fan speed: 4L per day (330 Watts) 20°C and 60%RH high fan: 7L per day (650 Watts) 30°C and 80%RH high fan: 8L per day (650 Watts)
Max Rated Input Power	650 W
Tank Capacity	2.5 litres
Noise level	30 dB(A)
Dimensions	300 x 200 x 455mm
Net Weight	5.7 kg
Operating temperature	-10°C to 50°C
All information provided is for reference only. Products specifications may change due to continuous product development.	

electriQ UK SUPPORT

For your own convenience, make these simple checks before calling the service line.

1. Has the unit been standing upright? (for at least 2 hrs)
2. Is the unit plugged into the mains? Is the fuse OK?
3. Switch the unit on and wait three minutes to see if the issue is resolved.
4. Check whether the water tank is full.
5. Have you followed the troubleshooting procedures?

If the unit still fails to operate call: 0330 390 3061 or fill in the online form

Office hours: 9AM - 5PM Monday to Friday

www.electriQ.co.uk
Unit J6, Lowfields Business Park
Lowfields Way, Elland
West Yorkshire, HX5 9DA

Disposal: Do not dispose of this product as unsorted waste. Collection of such waste must be handled separately as special treatment is necessary.



Recycling facilities are now available for all customers at which you can deposit your old electrical products. Customers will be able to take any old electrical equipment to participating sites run by their local councils. Please remember that this equipment will be further handled during the recycling process, so please be considerate when depositing your equipment. Please contact the local council for details of your local household waste recycling centre

DECLARATION OF CONFORMITY

Hereby, electriQ declares that this Portable air conditioner is in compliance with Directive 2014/53/ EU. The full text of the EU declaration of conformity is available at the following internet address:
<https://www.electriQ.co.uk/content/declaration-of-conformity>